

LION

PRECISION

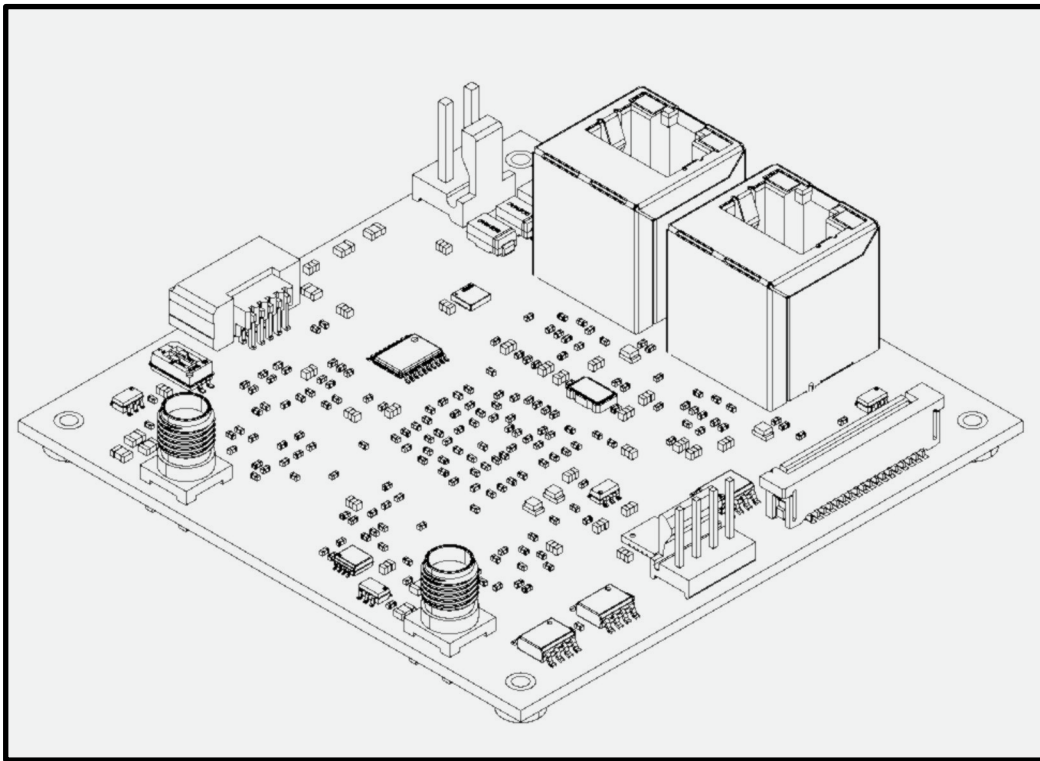

ECD311 - ECD312 USER'S GUIDE

Eddy-Current Sensor Systems

Oakdale, MN, USA www.lionprecision.com 651-484-6544

www.lionprecision.com/two-year-warranty/

TABLE OF CONTENTS

APPROVALS AND SAFETY CONSIDERATIONS	3
Helpful Technical Support Documents Online	3
ECD310 Eddy Current Displacement Sensor	4
Description	4
Basic Operation	4
Interpreting the output	4
Connectors Overviews	5
Power Input	5
External Temperature	5
On Board Temperature Sensor	6
SPI	6
RJ45 - EtherCAT	6
Status LED - EtherCAT	6
Feedback-EtherCAT	7
Board Profile	8
ECD310 Specifications¹	9

APPROVALS AND SAFETY CONSIDERATIONS

TBD

Helpful Technical Support Documents Online

Lion Precision's website has a large selection of technical documents (TechNotes and Application Notes) in the Technical

Library. These documents provide detailed descriptions of the operation and use of Lion Precision high-performance sensors.

The Technical Library can be accessed at:

<https://www.lionprecision.com/technical-library/>

ECD310 Eddy Current Displacement Sensor

Description

The Lion Precision ECD310 Eddy-Current Displacement Sensor provides high resolution, noncontact measurement of position changes of a conductive target. The system consists of driver electronics and a probe calibrated for a specific material and range. The calibration information is detailed on a calibration certificate which is shipped with the system. The ECD310 provides a linear digital output proportional to changes in the target position.

Basic Operation

The digital output can be accessed from two locations. LVDS SPI output via 10 pins connector on P6 or accessed via EtherCAT RJ45 on P3 (IN) and P4 (OUT). Digital data is presented by a 16-bit digital count from 0 to 65535 full scale where the calibrated range is from 6000 to 60000.

EtherCAT Slave Information (ESI) will be provided in XML format with all elements and attributes of dealing with the system defined.

Interpreting the output

The amount of change of the digital counts for a given change in the probe/target gap is called Sensitivity. The sensitivity of the sensor is listed on the calibration documents.

$$\text{Gap Change} = \frac{\text{Count Change}}{\text{Sensitivity}}$$

For example: With a sensitivity of 108 Counts/ μm and a count change of 648, the gap change would be 6 μm (648/108).

Connectors Overviews

Power Input

Male Header 2x Pins Connector P1 on the board is the power input. The manufacture part# of the connector is 640445-2 and the recommended mating connector are 770849-2, 3-640426-2 or 3-640428-2. Power Specification for more information on Specifications.

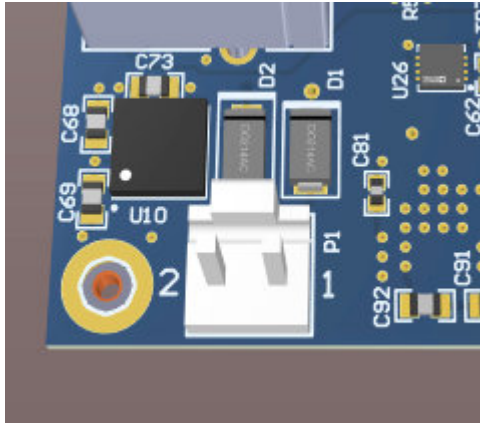

PINs	Connection
1	Power
2	Ground

External Temperature

Male Header 4x Pins Connector P2 is the input for external RTD temperature sensor and PT100 is recommended. The result will be available at every 2 Hz (0.5 second) with return of 16 bits count data . Result can be interpreted by the formula below. If customer would like to setup to others type of RTD sensors, please contact Lion Precision Support. Depending on the RTD sensor, the overall accuracy can be $\pm 1^{\circ}\text{C}$.

$$\text{Temperature } (^{\circ}\text{C}) \approx \left(\frac{\text{Temp Count}}{32} \right) - 256$$

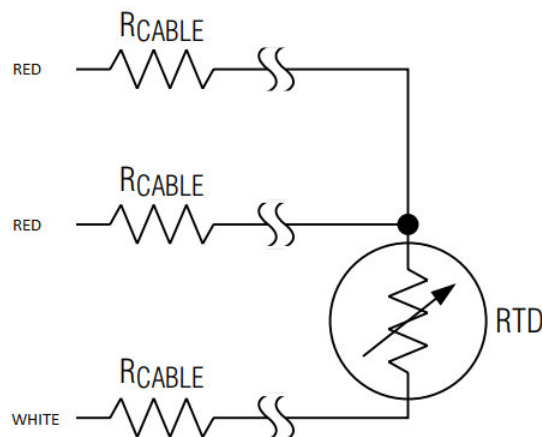

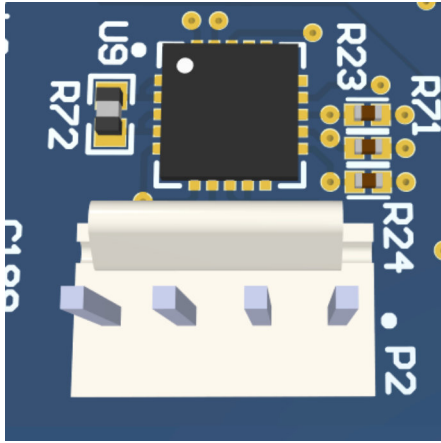

PINs	Connection
1	WHITE
2	RED
3	RED
4	Ground

On Board Temperature Sensor

The ECD310 has a on board temperature sensor which has accuracy of 1.5 °C within -10 °C to 60 °C. The result will be

available at every 0.2 Hz (5 second) with return of 13 bits count data. If the temperature reading is positive the counts can be interpreted with:

$$\text{Temperature (}^\circ\text{C)} \approx \text{TempCount} \times 0.0625$$

If the temperature reading is negative, the counts will need to be 2's complement and interpreted as below:

$$\text{Temperature (}^\circ\text{C)} \approx [\{ 2\text{'s Complemented} \} \text{TempCount}] \times 0.0625$$

SPI

TBD

RJ45 - EtherCAT

The ECD310 has two ports EtherCAT slave protocol which can be access through two RJ45. Annotation P3 is the IN and annotation P4 is the OUT. The hardware configuration is stored in a non-volatile memory (e.g. an EEPROM), the Slave Information Interface (SII), which contains information about the basic device features, so that the master can read this at boot-up and operate the device even if the device description file is not available. The EtherCAT Slave Information (ESI) file that comes with the device is XML based and contains the complete description of its network accessible properties, such as process data and their mapping options, the supported mailbox protocols including optional features, as well as the supported modes of synchronization. The ESI file will be provided through request from Lion Precision.

Status LED – EtherCAT

There is two GREEN (DS4) and RED LED (DS3) on the ECD310 which indicates the status of the EtherCAT state machine.

The Green LED is the RUN LED, and the Red LED is the ERROR LED. Table below shows the EtherCAT LEDs truth table

RUN LED	Slave State
Off	INIT
Blinking	PRE-OPERATIONAL
Single Flash	SAFE-OPERATIONAL
On	OPERATIONAL

ERROR LED	Slave State
Off	No Error
Blinking	Invalid Configuration
Single Flash	Local Error
Double Flash	Watchdog Timeout
On	Application Controller Failure

Feedback–EtherCAT

ECD310 EtherCAT slave protocol, there is a feedback address register and a return feedback register that the user can obtain the system information. Below are the register table,

Feedback Address (16 Bits)	Feedback Data Description	Type
X"3000"	Firmware Number	Unsigned 32 Bits
X"3001"	Firmware Revision	Unsigned 32 Bits
X"3002"	System Serial Number	Unsigned 32 Bits
X"3003"	Probe Serial Number CH1	Unsigned 32 Bits
X"3004"	Probe Serial Number CH2	Unsigned 32 Bits
X"3005"	Order Number	Unsigned 32 Bits
X"3006"	Order Number Extension	4 x ASCII Char
X"3007"	Calibration Date	32 bits Epoch & Unix Time
X"5000"	LinearPositionData1 & LinearPositionData2	Unsigned 31 DOWNT0 16 (CH1) Unsigned 15 DOWNT0 0 (CH2)
X"6000"	nonLinearPositionData1 & nonLinearPositionData2	Unsigned 31 DOWNT0 16 (CH1) Unsigned 15 DOWNT0 0 (CH2)
OTHERS	0	Unsigned 32 Bits

Board Profile

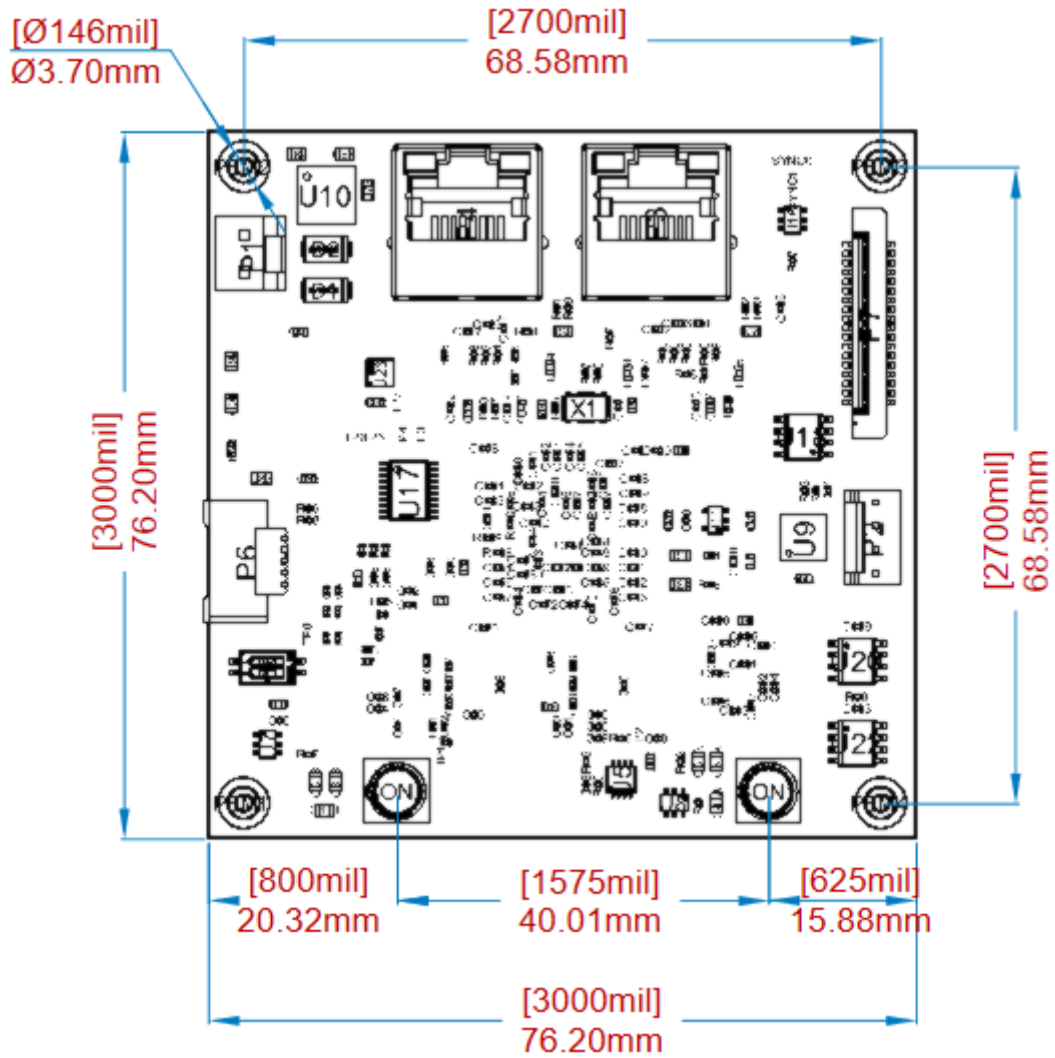

ECD310 Specifications¹

Table 1: General Specification

Input Power	12 – 36 VDC, 3 W
Linearity Error	± 0.3% F. S
Error Band	± 0.6% F. S
Operating Temperature	4 -50°C
Probe Operating Environment	-25°C to +125°C
Temperature Coefficient Driver	± 0.04 % F.S. / °C
Temperature Coefficient Probe	± 0.04 % F.S. / °C

¹ These specifications are typical for standard components and calibrations. Customizations can affect performance. Check the calibration sheet shipped with the product for specific details on your system.

In high EMI environments (10 V/m), output noise may rise to 0.2 VRMS (1% resolution) and DC output may shift.