

LION PRECISION



ECL101 USER'S GUIDE

Eddy-Current Displacement Sensor

TABLE OF CONTENTS

APPROVALS AND SAFETY CONSIDERATIONS	3
ECL101	3
Description	3
PROBE MOUNTING	3
EXTENSION CABLES	4
RANGE LED OPERATION	4
ZEROING THE OUTPUT	4
REMOTE ZERO	4
SYNCHRONIZED SYSTEM	4
FIELD CALIBRATION	5
DRIVER CONNECTIONS	5
SPECIFICATIONS	6
MORE INFORMATION	6

APPROVALS AND SAFETY CONSIDERATIONS

The ECL101 is compliant with the following CE directives:

Safety: 61010-1:2001

EMC: 61326-1, 61326-2-3

To maintain compliance with these standards, the following operating conditions must be maintained:

- All I/O connecting cables must be less than three meters in length
- AC power cables must be rated at a minimum of 250 V and 5 A
- AC power must be connected to a grounded mains outlet rated less than 20A
- Use the included CE approved power supply. If an alternative power supply is used, it must have equivalent CE certification and provide safety isolation from the mains according to IEC60950 or 61010.
- Sensors must not be attached to parts operating at hazardous voltages in excess of 30VRMS or 60VDC
- All external connections must be SELV (Safety Extra Low Voltage). Use of the equipment in any other manner may impair the safety and EMI protections of the equipment.

ECL101

Description

The ECL101 displacement sensor consists of a probe with integral coaxial cable and a driver which operates on 12-24V DC and produces a 0-10 VDC output which are linearly proportional to the distance between the probe and the target being sensed.

PROBE MOUNTING

Probes must be mounted to avoid interaction with the mounting hardware and interaction between adjacent probe fields. The distance between multiple probes must be at least 3 probe diameters. The area within 3 probe diameters to the sides and 1.5 diameters behind should be kept clear of adjacent probes or any metallic objects other than the object to be measured.

If this is not possible, field calibration may be required.

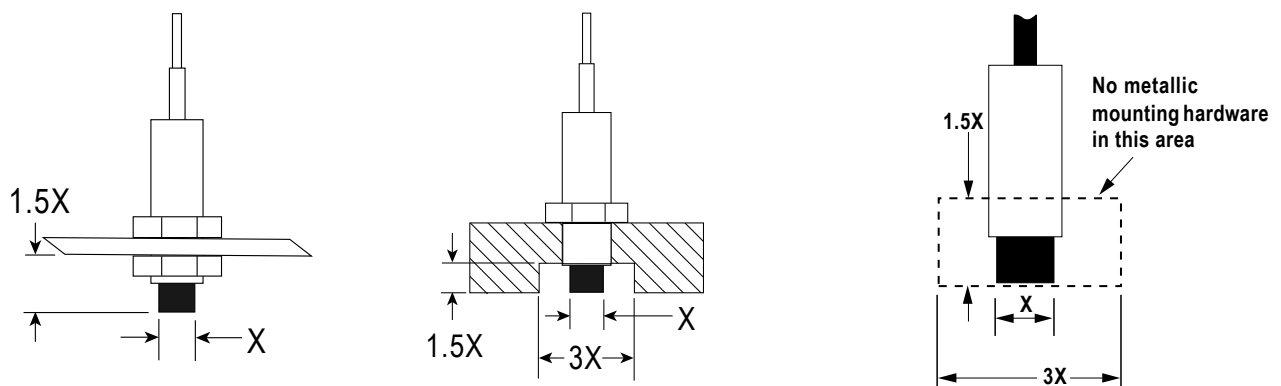

EXTENSION CABLES

If a probe extension cable is included, the sensor is calibrated with the extension cable attached. Operating the sensor without the extension cable may cause inaccurate results.

RANGE LED OPERATION

Dual color LEDs indicate the relative position of the target as shown at right. One LED is illuminated whenever power is applied.

ZEROING THE OUTPUT

The sensor is factory calibrated to produce an output of zero volts when the probe is at the Near Gap (nearest calibrated point) and the front panel Zero adjustment is at the center of its adjustment range. The front-panel Zero provides a $\pm 0.5V$ DC shift to the output.

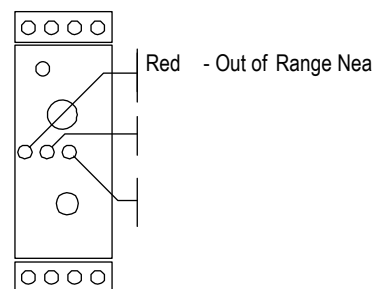

REMOTE ZERO

The output voltage can also be shifted by applying $\pm 10 V$ to the Remote Zero input. Positive voltage input shifts the output in a positive direction.

NOTE

Noise/ripple on the Remote Zero voltage will appear in the analog output.

SYNCHRONIZED SYSTEM

Sensor measuring the same target should be synchronized unless the sensors are too far apart to make it practical. Short coax interconnecting cables are provided with synchronized drivers. The cables interconnect the Sync connectors on the faces of the drivers. Do not use a T-connector on the Master Driver, identified with an "M" label. Slaves are identified with an "S" (formerly Primary "P" and Secondary "S").

FIELD CALIBRATION

Adjustments accessed from the bottom of the enclosure allow for field calibration. Any change in these adjustments will void the NIST traceable calibration certificate shipped with the sensor.

These instructions are for recalibration to the original range as shipped from the factory. Calibration to a significantly different range and/or offset will adversely affect the range LEDs operation, and temperature and resolution specifications.

A suitably precise method to accurately adjust the probe/target gap is required for calibration.

1. Position the front panel Zero adjustment to the mid point (25 turns in one direction, and 12 turns back will center the adjustment).
2. Set the probe/target gap to the minimum (offset).
3. Use the calibration Zero adjustment on the bottom of the device to set the output voltage to 0.00 VDC.
4. Position the probe/target gap to the mid-point of the range.
5. Use the calibration Gain (bottom of enclosure) to set the output to 5.00 VDC.
6. Position the probe/target gap to maximum.
7. Use the calibration Coarse or Fine Linearity (enclosure bottom) to set the output voltage to 10.00 VDC.
8. Repeat steps 2-7 until no further adjustments are needed (see hint below).

HINT

When adjusting linearity, adjust the output for the same but opposite amount of error voltage. For example, if the output is 9.950 VDC adjust it to 10.050 VDC. This will shorten the total number of iterations of steps 2-7.

As the linearity adjustment approaches 10 VDC, use Fine Linearity for finer control.

DRIVER CONNECTIONS

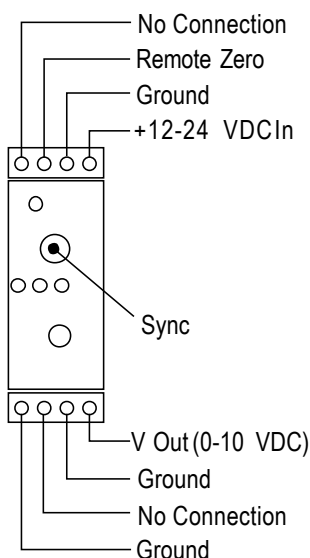

No Connection	
Remote Zero	± 10 VDC input shifts output voltage. Noise or ripple on this voltage will appear in the output voltage.
Ground	Internally connected to power input ground.
VDC In	+12 to +24VDC @2W power input. Input voltage ripple must be less than 40mV p-p to maintain specifications.
V Out	0-10VDC calibrated output. Actual output voltage can range from -5 to +Vin when probe is out of range.
V Out Ground	Internally connected to power input ground.
No Connection	
Ground	Internally connected to power input ground.
Sync	Synchronization connection. Maximum of 1 master and 8 slaves.

SPECIFICATIONS

Analog Output		0-10 VDC, 0 Ω , 15 mA max
Resolution*		0.008% typical dependent on calibration
Linearity		0.05%
Probe Thermal Drift at Mid-Range		$\pm 0.04\%$ FS/ $^{\circ}$ C
Input Power		12-24 VDC, 2 W
Remote Offset (Zero)		± 10 VDC analog voltage
Driver Operating Environment		4 $^{\circ}$ C to 50 $^{\circ}$ C, IP40
Probe Operating Environment	Standard Probes	-25 $^{\circ}$ C to 125 $^{\circ}$ C, IP67
	High Temperature Probes	-25 $^{\circ}$ C to 200 $^{\circ}$ C, IP63

* Specifications are based on Aluminum and/or 4140 Steel targets.

In high EMI environments (10 V/m) output level may shift and noise levels may rise to 50 mV RMS (0.5% resolution)

MORE INFORMATION

For more detailed information on the theory of operation and application of eddy-current displacement sensors, visit our web site at www.lionprecision.com.

For applications assistance or customer service: Call 651-484-6544,

E-mail: info@lionprecision.com

Be confident when you do **business with Lion Precision**