

# LION

---

## PRECISION



# ECL202/ECL202e USER'S GUIDE

Eddy-Current Displacement Sensor

# TABLE OF CONTENTS

---

<b>APPROVALS AND SAFETY CONSIDERATIONS</b>	<b>3</b>
<b>ECL202 AND ECL202e</b>	<b>3</b>
Description	3
<b>QUICK START INSTRUCTIONS</b>	<b>3</b>
<b>FRONT PANEL CONTROLS AND INDICATORS</b>	<b>4</b>
LED Range Indicator	4
Offset Button	4
Resetting Offset	4
Setpoint Button	5
<b>ANALOG OUTPUT SIGNAL</b>	<b>5</b>
Interpreting the Output Voltage	5
Change in gap calculation:	5
<b>REMOTE OFFSET AND SETPOINT</b>	<b>5</b>
<b>SETPOINT SWITCH OUTPUT</b>	<b>5</b>
<b>BANDWIDTH SELECTION (ECL202 ONLY)</b>	<b>5</b>
<b>MAXIMIZING PERFORMANCE</b>	<b>6</b>
Extension Cables	6
Probe Mounting	6
Ungrounded Targets	6
Multiple Sensors	6
<b>CONNECTING TO THE ECL202</b>	<b>7</b>
<b>SPECIFICATIONS</b>	<b>9</b>
<b>MECHANICAL DETAIL</b>	<b>11</b>

# APPROVALS AND SAFETY CONSIDERATIONS

---

The ECL202/ECL202e is compliant with the following CE directives:

**Safety:** 61010-1:2001

**EMC:** 61326-1, 61326-2-3

To maintain compliance with these standards, the following operating conditions must be maintained:

- All I/O connecting cables must be less than three meters in length
- AC power cables must be rated at a minimum of 250 V and 5 A
- AC power must be connected to a grounded mains outlet rated less than 20 A
- Power supply must have CE certification and provide safety isolation from the mains according to IEC60950 or 61010.
- Sensors must not be attached to parts operating at hazardous voltages in excess of 30 VRMS or 60 VDC
- All external connections must be SELV (Safety Extra Low Voltage).

Use of the equipment in any other manner may impair the safety and EMI protections of the equipment.

## ECL202 AND ECL202e

---

The ECL202e is identical to the ECL202 except that the ECL202e resolution is never better than 0.2  $\mu\text{m}$ . For this reason, the ECL202e does not require an export license.

This manual will only refer to the ECL202, but all instructions apply to the ECL202e except where noted.

### Description

The Lion Precision ECL202 Eddy-Current Displacement Sensor provides high resolution, noncontact measurement of position changes of a conductive target. The system consists of driver electronics and a probe calibrated for a specific material and range. The calibration information is detailed on a calibration certificate which is shipped with the system.

The ECL202 provides a linear analog voltage proportional to changes in the target position and a digital switched (setpoint) output with a user programmed switching setpoint.

## QUICK START INSTRUCTIONS

---

1. Connect the probe to the ECL202.

<b>NOTE</b>
-------------

**The ECL202 is calibrated to a specific probe identified by serial number. The probe serial number must match the "USE PROBE S/N" label on the front of the ECL202.**

2. Connect the output to a monitoring device.
3. Connect then apply power.
4. Adjust the probe position so the Range Indicator shows green

# FRONT PANEL CONTROLS AND INDICATORS

## LED Range Indicator

The Range Indicator monitors and displays the probe position within its calibrated range. The graphic below shows the indicator condition at various points within the calibrated range.

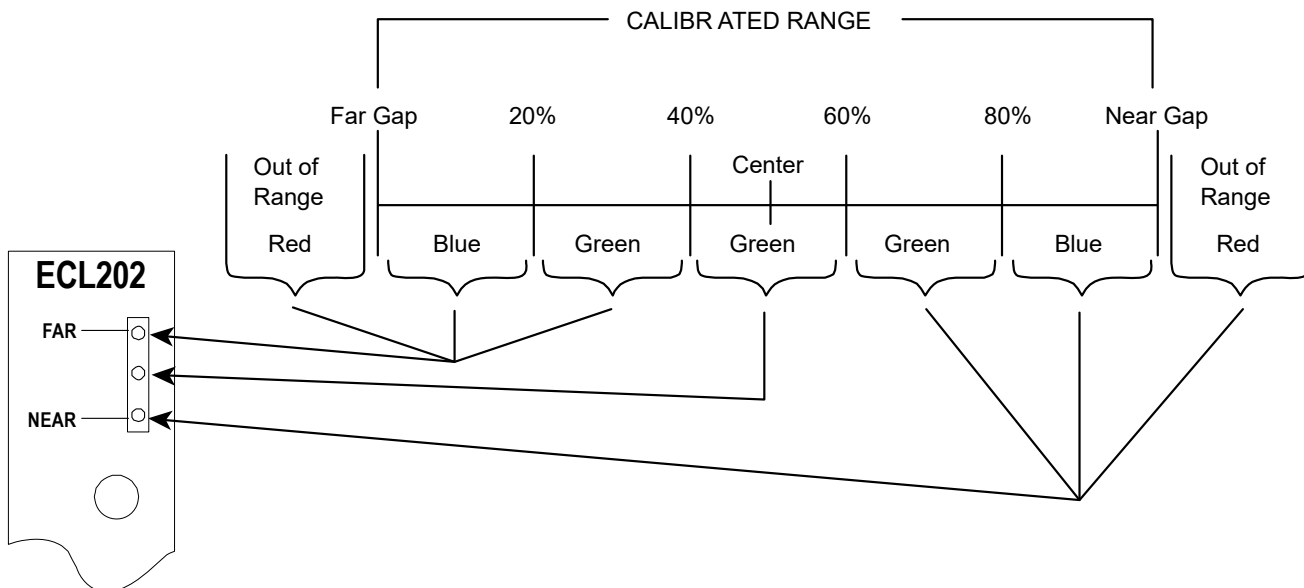

The LED Range Indicator is independent of the output voltage and not affected by the Offset button. Shifting the output voltage by using the Offset button may allow an apparently valid output voltage to exist while the probe is out of range. When the Near or Far LED is red, the probe is out of range and the output voltage is not a reliable indication of the target position.

## Offset Button

Pushing the Offset button shifts the DC level of the output voltage to the center of the voltage range (i.e. 5 V for a 0-10 V output). The button will only function when the probe is in the center 20% of its calibrated range (center green LED). If the center green LED on the Range Indicator is not on, the Offset button will not function.

This function establishes a repeatable master point for reference measurements.

1. Place good part in the measurement area
2. Position probe to center 20% of range (center indicator LED)
3. Press Offset button
4. All subsequent measurements indicate deviation from center of range (5 V)

## Resetting Offset

Hold the Offset button for four seconds to remove any output DC shift.

## Setpoint Button

The ECL202 provides an adjustable setpoint at which a switched output activates. The output switch closes when the output voltage is more positive (larger gap) than the user-adjusted setpoint. Pressing the Setpoint button will set the threshold voltage to the current output voltage. The setpoint includes a 0.085V hysteresis, requiring that the sensor output drop 0.085V below the setpoint voltage before the switched output opens.

## ANALOG OUTPUT SIGNAL

---

The output signal is an analog voltage of 0-10 VDC. The output voltage is proportional to the probe-target gap. As the probe-target gap increases, the voltage becomes more positive. See the included calibration certificate for specific information.

### Interpreting the Output Voltage

Output voltage change for a given change in the probe-target gap is called sensitivity. The sensitivity is listed on the calibration certificate.

### Change in gap calculation:

$$\text{Gap Change} = \text{Voltage Change} / \text{Sensitivity}$$

For example: With a sensitivity of 1V/2  $\mu\text{m}$  and a voltage change of +3 V, the probe-target gap has increased by 6  $\mu\text{m}$ .

## REMOTE OFFSET AND SETPOINT

---

The front panel Offset and Setpoint buttons can be activated remotely. Each remote input connects to an optoisolator. The functions are activated by applying 15-24 V to the remote control input terminals.

NOTE
------

**Because the remote operation mimics front panel operation, activating the Offset function for more than four seconds will restore factory default value for Offset.**

## SETPOINT SWITCH OUTPUT

---

When the output voltage is more positive than the user adjusted setpoint voltage, the output switch contacts will close. These contacts have a maximum resistance of 2.5  $\Omega$  and can conduct up to 250 mA. The maximum voltage that can be switched is 30VAC/60VDC. The output is a solid state switch closure and can conduct AC or DC.

## BANDWIDTH SELECTION (ECL202 ONLY)

---

A jumper wire on the bandwidth connector selects sensor bandwidth. To select a bandwidth, connect the desired bandwidth terminal to the Bandwidth Select contact. With no jumper, the bandwidth is 15 kHz. Bandwidth specifications are -10%/+30%.

# MAXIMIZING PERFORMANCE

## Extension Cables

Sensors which are calibrated with a probe extension cable must be operated with the extension cable to meet specifications. Operating without the extension cable will result in inaccurate measurements.

## Probe Mounting

If multiple probes are mounted together, they must be separated by at least three probe diameters.

The area within 3 probe diameters to the sides and 1.5 diameters behind should be kept clear of any metallic objects other than the object to be measured. Otherwise, custom calibration will be required.

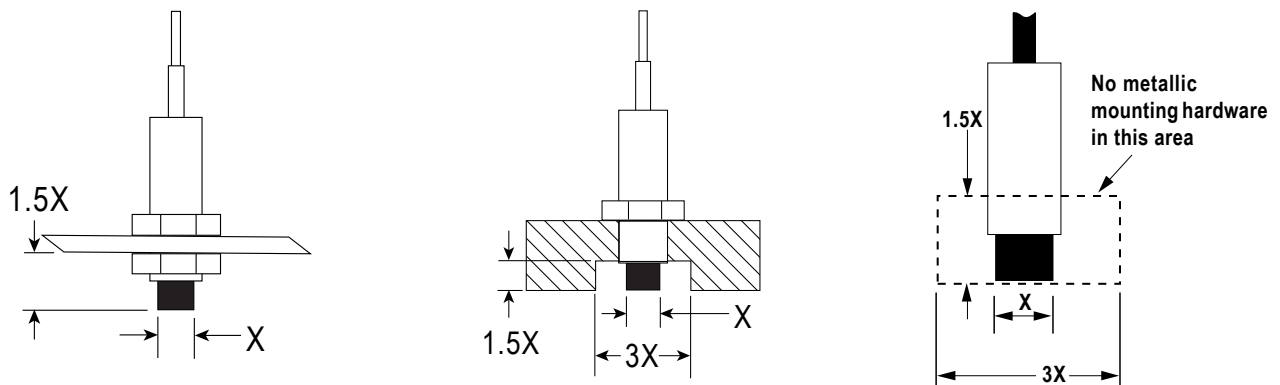

## Ungrounded Targets

Ungrounded targets have the potential to inject noise into the sensor. If the output is unusually noisy, be sure the target is grounded. On moving/rotating targets this can be accomplished with a small metal brush or thin piece of metal which is connected to ground.

## Multiple Sensors

When multiple sensors are used with the same target, the sensors must be synchronized. An interconnecting circuit board connects to the rear of multiple drivers to provide synchronization signals. Multiple sensor orders are shipped with the interconnect board in place and the drivers are pinned together as one unit.

### CAUTION

**It is critical that each ECL202 be connected to the probe indicated on the "USE PROBE S/N" label on the front of each ECL202.**

# CONNECTING TO THE ECL202

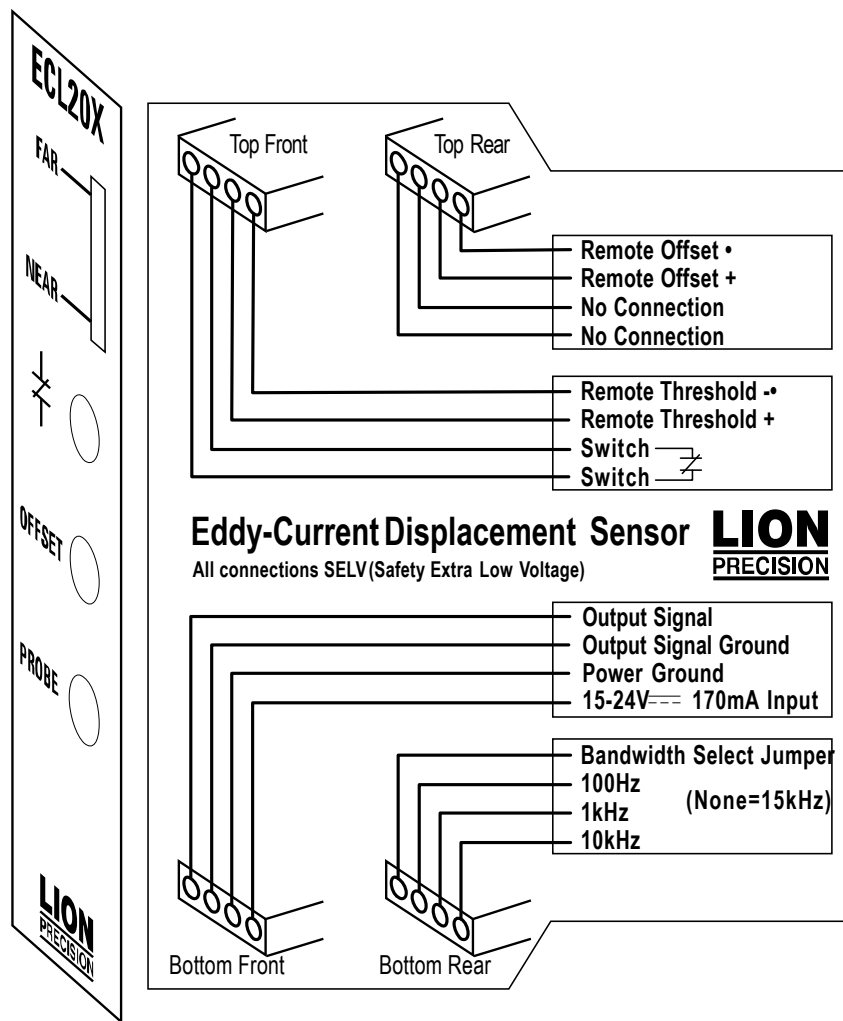

Connection	Description	Notes
Top-Rear Connector: Remove Offset		
No Connection		
No Connection		
Remote Offset +	+ Optoisolator input for Remote Offset function	15-24 VDC Activates the function
Remote Offset -	- Optoisolator input for Remote Offset function	
Top-Front Connector: Remote Setpoint and Switch Output		
Remote Threshold -	- Optoisolator input for Setpoint function	15-24 VDC Activates the function
Remote Threshold +	+ Optoisolator input for Setpoint function	
Switch	Contact 1 of switched output	Open: 30 VAC/60 VDC max Closed: 250 mA max
Switch	Contact 2 of switched output	

Connection	Description	Notes
Bottom-Front Connector: Power and Analog Output		
Power In	Input Power	Internally connected together
Power Ground	Power Ground	
Output Signal Ground	Reference for output signal voltage	
Output Signal	Output signal voltage	0-10 VDC
Bottom-Rear Connector: Bandwidth ( <b>ECL202 Only</b> )		
Bandwidth Selected	Common point for bandwidth selection jumper	
100Hz, 1kHz, 10kHz	Bandwidth selection, connected to Bandwidth Selected	None = 15 kHz



# SPECIFICATIONS

Parameter		Specification	Notes
Power Requirement		15-24 VDC, 2.5 W	
Resolution @ 15kHz (Typical) <sup>1,2</sup>	nonferrous	0.006 to 0.008%F.S. (ECL202) 0.3 μm or higher (ECL202e)	See calibration sheet for specifics
	ferrous	0.007 to 0.1%F.S. (ECL202) 0.3 μm or higher (ECL202e)	
Linearity <sup>1</sup>		±0.2%F.S.	
Error Band <sup>1</sup>		±0.4%F.S.	
Analog Output <sup>1</sup>		0-10 VDC, 0 Ω, 15 mA max	
Analog Output Update Rate		15 μS	
Setpoint Switch Output		Solid state switch closure: On state: 2.5 Ω, 250 mA max Off state: 30 VAC/60 VDC max	
Remote Setpoint and Offset Inputs		15-24 VDC to activate, 3-7 mA	Optoisolator inputs
Driver Operating Environment		4°C-50°C, IP40	
Probe Operating Environment	Standard Probes	-25°C to +125°C, IP67	
	High Temp. Probes	-25°C to +200°C, IP63	

<sup>1</sup>Actual values depend on probe and range and are listed on the calibration certificate shipped with the product. Contact Lion Precision for replacement certificates.

<sup>2</sup>In High EMI environments (10 V/m), output noise levels may rise to 30 mV causing resolution to be reduced to 0.3%.

Parameter		Specification		Notes
Temperature Coefficient Driver	Nonferrous	U3 Probe	±0.04% F.S./°C	Over 15°C to 50°C temperature range
		U5 Probe	±0.1% F.S./°C	
		U8 Probe	±0.04% F.S./°C	
		U12 Probe		
		U18 Probe		
		U25 Probe		
		U38 Probe		
		U50 Probe		
	Ferrous	U3 Probe	±0.08% F.S./°C	
		U5 Probe	±0.1% F.S./°C	
		U8 Probe	±0.04% F.S./°C	
		U12 Probe		
		U18 Probe		
		U25 Probe		
		U38 Probe		
		U50 Probe		
Temperature Coefficient (Probe)	Nonferrous	U3 Probe	±0.04% F.S./°C	Over 15°C to 65°C temperature range
		U5 Probe	±0.04% F.S./°C	
		U8 Probe	±0.02% F.S./°C	
		U12 Probe	±0.02% F.S./°C	
		U18 Probe	±0.01% F.S./°C	
		U25 Probe		
		U38 Probe		
		U50 Probe		
	Ferrous	U3 Probe	±0.04% F.S./°C (15°C to 35°C) ±0.08% F.S./°C	
		U5 Probe	±0.01% F.S./°C	
		U8 Probe	±0.04% F.S./°C	
		U12 Probe	±0.03% F.S./°C	
		U18 Probe	±0.01% F.S./°C	
		U25 Probe	±0.01% F.S./°C	
		U38 Probe	±0.02% F.S./°C	
		U50 Probe	±0.01% F.S./°C	

# MECHANICAL DETAIL

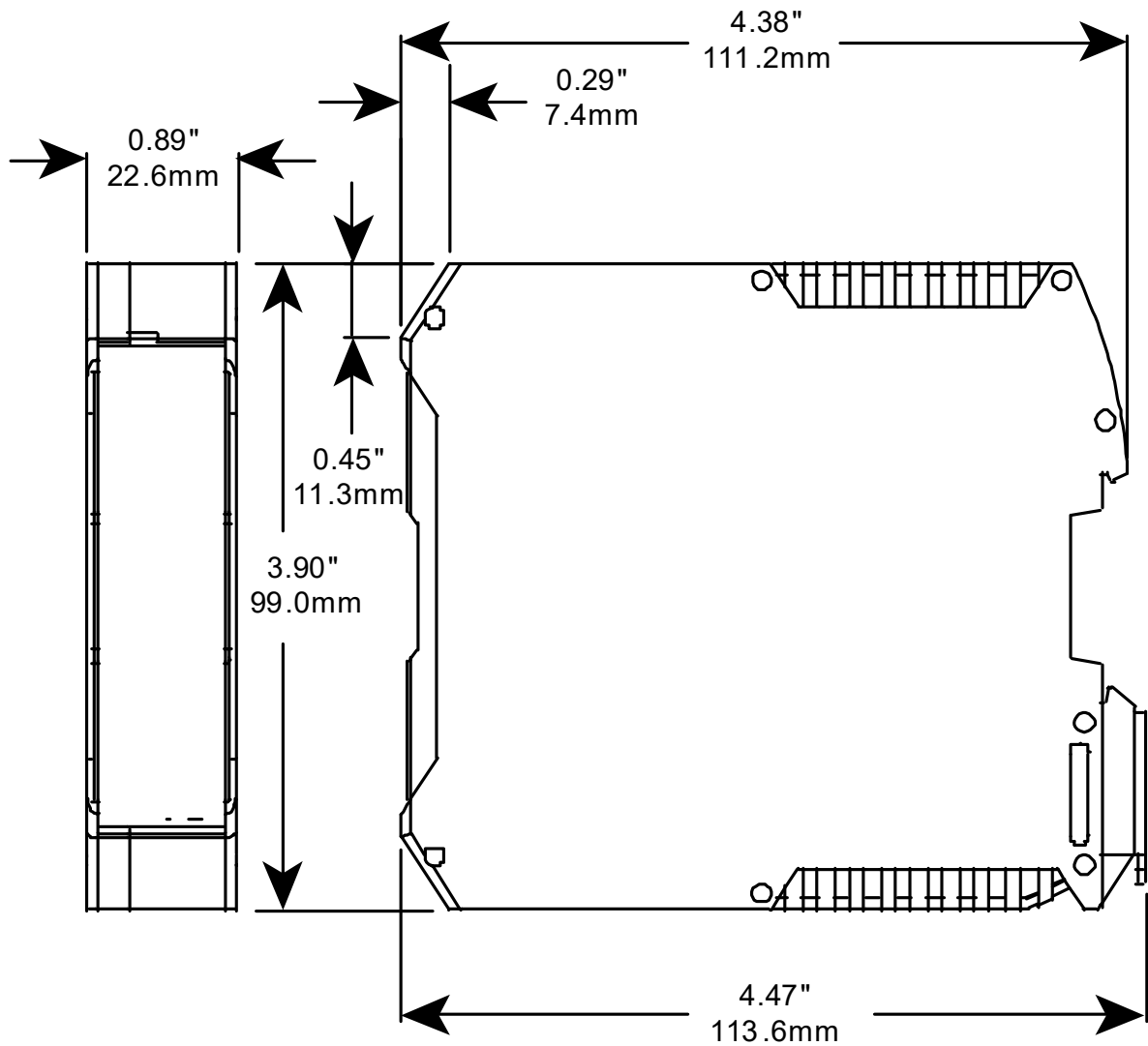

Be confident when you do  
**business with Lion Precision**