

LION

PRECISION



CPL230 USER'S GUIDE

Multi-Channel Capacitive Sensor System

TABLE OF CONTENTS

APPROVALS AND SAFETY CONSIDERATIONS	3
OVERVIEW	3
SYSTEM CONTENTS	3
IDENTIFYING PROBE/CHANNEL	3
The Elite Series is compliant with the following CE standards:	3
CALIBRATION	4
PROBE EXCITATION SIGNAL PHASING	4
USING THIS MANUAL	4
GETTING HELP	4
TECHNICAL LIBRARY	4
CONNECTING TO THE CPL230	5
Probe Connections	5
To Connect the Probes	5
To Disconnect the Probes	5
POWER SUPPLY CONNECTIONS	5
Power Supply Requirements	5
Power IN Connector	5
Pin Assignments	5
ANALOG OUTPUT CONNECTIONS	6
DIFFERENTIAL OUTPUTS	6
SINGLE-ENDED OUTPUTS	6
SIGNAL GROUND CONNECTIONS	6
ANALOG OUTPUT CONNECTOR	6
PIN ASSIGNMENTS	6
CHANGING THE BANDWIDTH	7
SPECIFICATIONS	7
MECHANICAL DATA	8

APPROVALS AND SAFETY CONSIDERATIONS

The Elite Series is compliant with the following CE standards:

Safety: EN 61010-1:2010

EMC: IEC 61326-1:2013, IEC 61326-2-3:2013

To maintain compliance with these standards, the following operating conditions

must be maintained:

- All I/O connecting cables must be shielded and less than three meters in length
- AC power cables must be rated at a minimum of 250V and 5A
- AC power must be connected to a grounded mains outlet rated less than 20A
- Use the included CE approved power supply with 1-, 2-, and 3- slot enclosures. If an alternative power supply is used, it must have equivalent CE certification and provide safety isolation from the mains according to IEC60950 or 61010.
- Sensors must not be attached to parts operating at hazardous voltages in excess of 33VRMS or 70VDC

Use of the equipment in any other manner may impair its safety and EMI protections.

OVERVIEW

The CPL230 Multi-Channel Capacitive Displacement Sensor provides up to six channels of noncontact displacement measurement for precision position and displacement applications. This manual will provide you with all the information you require to get the greatest benefit from your system.

Engineers, technicians, and maintenance personnel will find the CPL230 invaluable for high-precision measurements of mechanical displacement where contact with the target is not possible nor advisable. Targets such as high-speed rotating spindles, or parts that could be damaged or deflected by contacting probes can be measured with confidence and accuracy.

Your CPL230 may have been ordered with one to six channels of capacitive sensing.

SYSTEM CONTENTS

Your system includes this manual, the CPL230 Multi-Channel Capacitive Sensor electronics, power supply, one probe for each channel, and a NIST traceable calibration sheet for each channel. Each channel has been specifically calibrated to a probe according to the specifications on your order. For this reason, each probe is color coded for a particular channel. Be sure the probes are used with the proper channel.

IDENTIFYING PROBE/CHANNEL

Individual probes are calibrated to specific channels of specific systems. Probes are color coded at both ends of the cable with small, colored rings; each channel of the electronics is color coded to match its designated probe.

Each CPL230 has calibration labels affixed to the end panel of the enclosure. Each label lists probe serial numbers and the channel to which they are calibrated. This information can be used should it become necessary to verify the probe/channel relationships beyond the color coding.

CALIBRATION

Your system was calibrated with a precision calibrator designed by Lion Precision. The system is calibrated with nanometer precision. All of our calibrations are traceable to NIST.

Lion Precision recommends that you have your system recalibrated at the factory once a year to ensure maximum accuracy.

PROBE EXCITATION SIGNAL PHASING

The excitation voltage from the probe creates a current flow through the target. When using a single probe, the current flows through the target to ground. If the target is not connected to ground, some small errors may occur relative to objects near the target including operator's hands. These errors are small and are only relevant when measuring with highest precision.

When using multiple probes, they can be configured so the current flows into and out of the probes and the current does not flow to ground. This reduces the errors due to a target not connected to ground.

A CPL230 with two or more channels is configured for all probes to be measuring the same target and result in very little target-to-ground current.

When using a target connected to ground, the multi-channel configuration has no effect and the probes can be used in any combination.

USING THIS MANUAL

In this manual you will find information for connecting to your CPL230 and instructions for setting up probe position. Once you become familiar with the system, you will only need to refer occasionally to this manual for specifications or to verify connection information.

GETTING HELP

Lion Precision wants to help you get the most from your system. If there is anything we can do, contact us:

Telephone: 800-292-6544, 651-484-6544

General information: info@lionprecision.com

Service or calibration: support@lionprecision.com

Sales: sales@lionprecision.com

TECHNICAL LIBRARY

Our website includes a Technical Library filled with useful information on making the most precise measurements possible, as well as product information and manuals: www.lionprecision.com, click the Technical Library menu item.

CONNECTING TO THE CPL230

Probe Connections

The CPL230 has one probe connector per channel. Each probe is color coded to its designated channel.

To Connect the Probes

1. Insert the probe connector into the corresponding CPL230 channel connector.
2. Rotate until the red dots on the connectors align.
3. Push the connector in until it clicks.

To Disconnect the Probes

1. Pull on the knurled barrel of the probe connector which will release the latching mechanism.

CAUTION

The probe cannot be disconnected by pulling on the cable.

The probes must be connected to their designated channels for proper operation.

POWER SUPPLY CONNECTIONS

Power Supply Requirements

The power supply provided with your CPL230 provides the required $\pm 15\text{VDC}$ input power. If using your own power supply, be aware that high-frequency noise from power supply lines may appear in the output. For high-resolution results, be sure to provide clean power.

Connect power through POWER IN, or ANALOG OUTPUT connector.

Power IN Connector

9-Pin, Male, D-Sub connector with 4-40 mounting hardware.

Pin Assignments

Pin	Connection
1	Ground
2	NC
3	-15 VDC
4	+15 VDC
5	NC
6	NC
7	NC
8	NC
9	NC

ANALOG OUTPUT CONNECTIONS

Analog outputs for each channel are provided by the ANALOG OUTPUT connector. See table below for pinout.

Analog outputs are intended to be used differentially and are calibrated accordingly. Calibration sheets will indicate Differential Output.

DIFFERENTIAL OUTPUTS

The Non-Inverted and Inverted outputs are used together as a differential output. Differential outputs help eliminate electrical noise induced into the connecting wires by noise sources such as computers, power transformers etc.

The Non-Inverted output voltage becomes more positive (relative to ground) as the probe nears the target. The Inverted output voltage becomes more negative (relative to ground) as the probe nears the target. The Non-Inverted and Inverted outputs are each ± 5 VDC relative to ground; the differential output is therefore ± 10 VDC.

The analog output connection pins are located to allow for twisted pair ribbon cable for maximum differential noise reduction.

CAUTION Do NOT connect the outputs to ground or the unit will be damaged.

SINGLE-ENDED OUTPUTS

The Non-Inverted or Inverted outputs can be used as a ground referenced single ended output, but the sensitivity will be half of that indicated on the calibration sheet. For instance, a differential output calibrated for 1 V/mm will produce 0.5 V/mm when used as a single-ended output.

SIGNAL GROUND CONNECTIONS

A ground connection screw is provided for an optional ground connection to data acquisition devices. Connecting the CPL230 ground and data acquisition ground may improve performance. Consult your data acquisition manual for more details.

ANALOG OUTPUT CONNECTOR

15-Pin, Female, D-Sub connector with 4-40 mounting hardware.

PIN ASSIGNMENTS

Analog Outputs (Warning: Do NOT connect analog outputs to ground!)			
Pin	Non Inverted Output	Pin	Inverted Output
1	Ch1 Noninverted	9	Ch1 Inverted
2	Ch2 Noninverted	10	Ch2 Inverted
3	Ch3 Noninverted	11	Ch3 Inverted
4	Ch4 Noninverted	12	Ch4 Inverted
5	Ch5 Noninverted	13	Ch5 Inverted
6	Ch6 Noninverted	14	Ch6 Inverted
Power In			
Pin	Connection	Pin	Connection
7	+15VDC	15	Ground
8	-15 VDC		

CHANGING THE BANDWIDTH

Higher bandwidths allow you to accurately measure faster moving targets. Lower bandwidth reduces the noise on the output and creates higher resolution. The CPL230 is set to 15 kHz unless specified otherwise in the order and on the calibration sheet received with the system.

Two switches inside the enclosure set the bandwidth for all channels. To change them:

Remove the 4 screws at the base of the driver and remove the cover.

Bandwidth is controlled by positions 1 and 2 of DIP-switch S2.

CAUTION DO NOT CHANGE ANY OTHER SWITCHES

Set the desired bandwidth according to the this table:

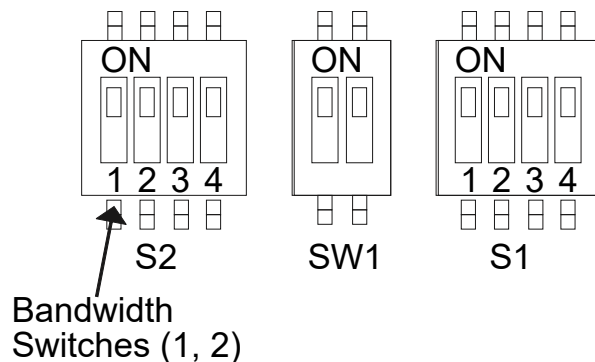

SPECIFICATIONS

Resolution*	0.004%F.S. at 15 kHz typical, dependent on calibration
Linearity Error	±0.5% F. S. typical, dependent on calibration
Error Band	±1.0% F. S. typical, dependent on calibration
Bandwidth (-3 db)	DIP Switch selectable 100 Hz, 1 kHz, 10 kHz, 15 kHz (-10%+30%)
Operating Temperature	4°-50°C
Probe Thermal Stability	0.04% F.S./°C
Output Impedance	0Ω
Output Voltage Max	±13.5 VDC
Output Max Current	20 mA
Power Input	+15 VDC (±5%) @ 500 mA max -15 VDC (±5%) @ 500 mA max

* RMS; Peak-to-peak value are typically 8-10 times greater than the RMS values. In high EMI conditions (10 V/m), output DC level may shift and noise may rise to 0.25 VRMS (1.3% resolution).

MECHANICAL DATA

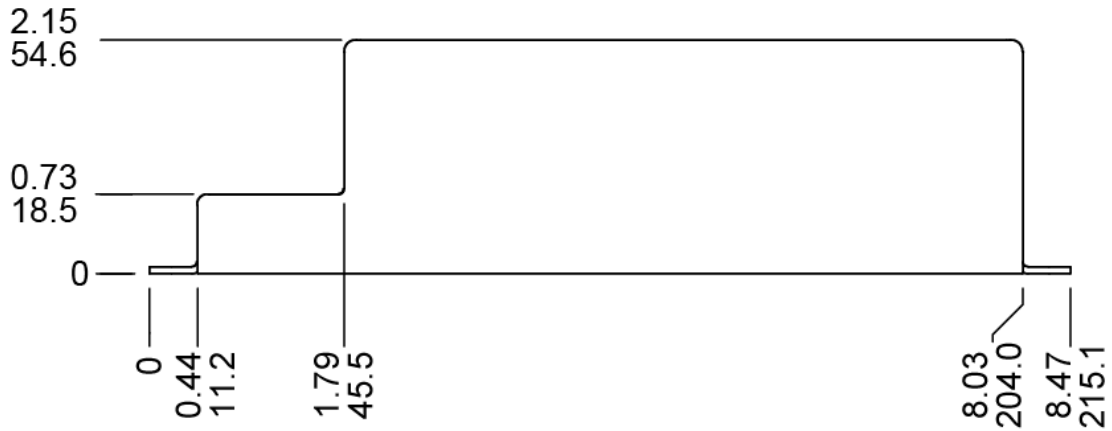
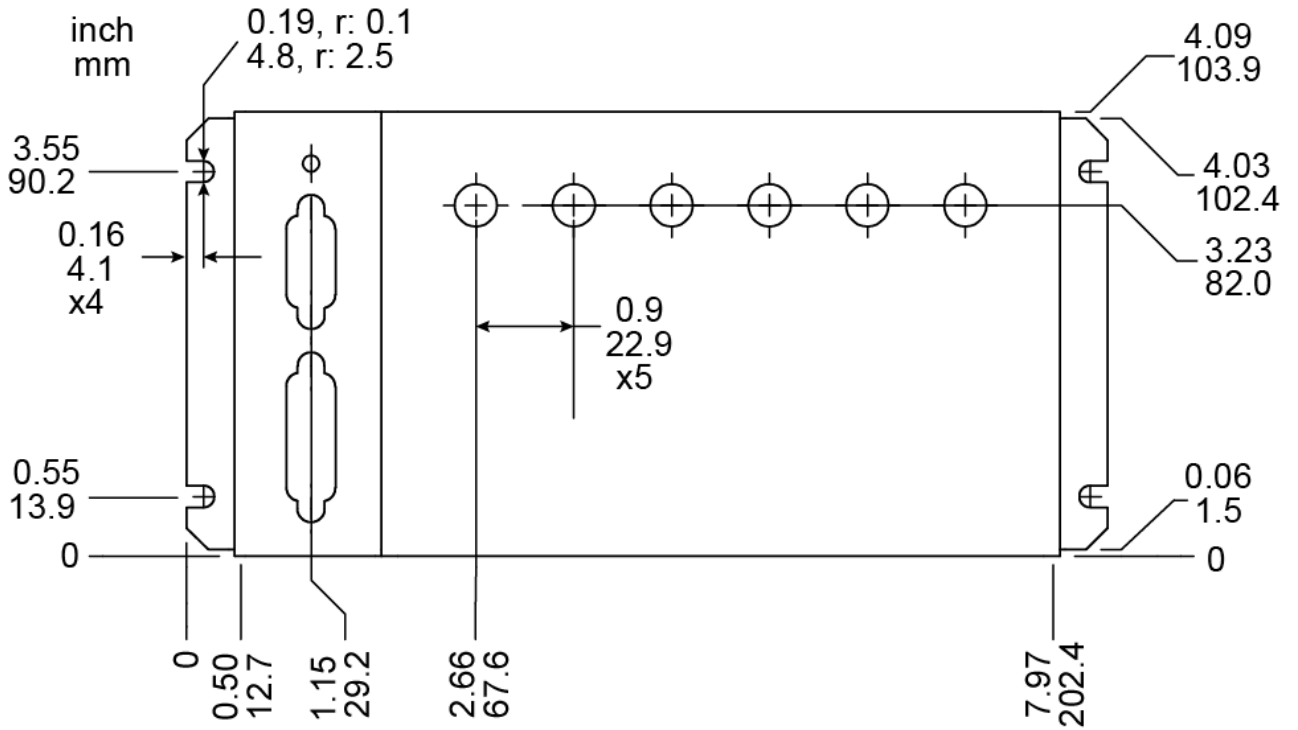

Be confident when you do **business with Lion Precision**